



Cambridge International Examinations
Cambridge International General Certificate of Secondary Education

CANDIDATE
NAME

CENTRE
NUMBER

--	--	--	--	--

CANDIDATE
NUMBER

--	--	--	--



CO-ORDINATED SCIENCES

Paper 3 (Extended)

0654/32

May/June 2015

2 hours

Candidates answer on the Question Paper.

No Additional Materials are required.

READ THESE INSTRUCTIONS FIRST

Write your Centre number, candidate number and name on all the work you hand in.

Write in dark blue or black pen.

You may use an HB pencil for any diagrams, graphs, tables or rough working.

Do not use staples, paper clips, glue or correction fluid.

DO NOT WRITE IN ANY BARCODES.

Answer **all** questions.

Electronic calculators may be used.

You may lose marks if you do not show your working or if you do not use appropriate units.

A copy of the Periodic Table is printed on page 32.

At the end of the examination, fasten all your work securely together.

The number of marks is given in brackets [] at the end of each question or part question.

This document consists of **30** printed pages and **2** blank pages.

- 1 (a) Fig. 1.1 shows a passenger at an airport pulling a suitcase towards the check-in desk.



Fig. 1.1

The suitcase has a mass of 18.4 kg and a weight of 180 N.

- (i) Explain the difference between the terms *mass* and *weight*.

.....

 [2]

- (ii) Calculate the Earth's gravitational field strength g in N/kg.

$g = \dots\dots\dots$ N/kg [1]

- (iii) The suitcase is pulled for a distance of 30 metres using a force of 20 N.

Calculate the work done in pulling the suitcase.

State the formula that you use and show your working.

formula

working

work done = J [2]

- (iv) Fig. 1.2 shows the suitcase being loaded onto an aircraft using a conveyor belt. The suitcase of mass 18.4 kg is lifted 3.0 m from the ground into the aeroplane.

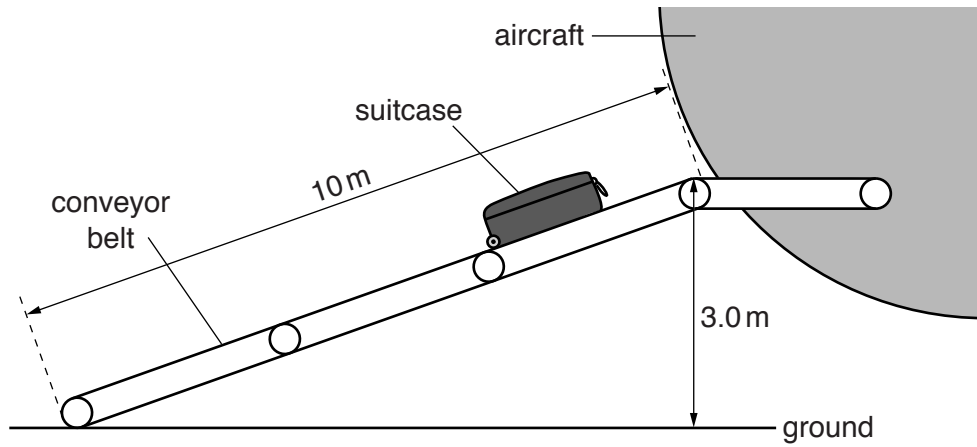

Fig. 1.2

Use your answer to (ii) to calculate the increase in the gravitational potential energy of the suitcase.

State the formula that you use and show your working.

formula

working

..... J [2]

- (b) An aircraft has a mass of 350 000 kg. It has four engines each of which produces a maximum force of 250 000 N.

Calculate the maximum acceleration of the aircraft.

State the formula that you use, show your working, and state the unit of your answer.

formula

working

maximum acceleration = unit [3]

- 2 Sulfur is a yellow crystalline, non-metallic element.

Sulfur combines with other elements to form compounds that include

magnesium sulfate, MgSO_4

hydrogen sulfide, H_2S

sodium sulfide, Na_2S .

- (a) (i) Suggest reactants that could be used to produce an aqueous solution of the salt, magnesium sulfate.

.....

..... [2]

- (ii) State the names of any other products that are formed in the reaction you have described in (i).

..... [1]

- (b) Hydrogen sulfide is a gaseous compound and sodium sulfide is a solid at room temperature. One of these compounds contains covalent chemical bonds and the other contains ions.

Fig. 2.1 shows diagrams of atoms of hydrogen, sodium and sulfur.

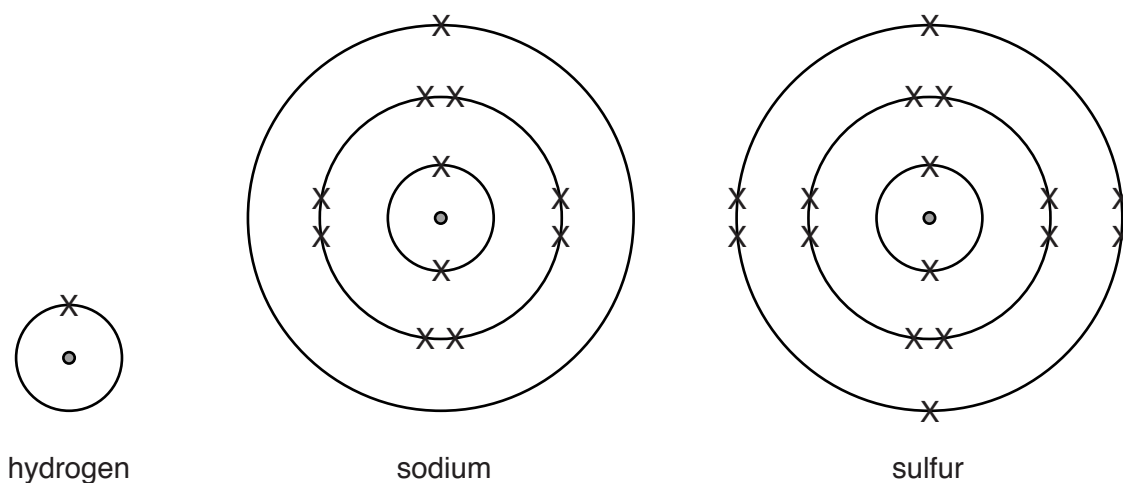

Fig. 2.1

Draw bonding diagrams to show how the outer electrons of these atoms are arranged in hydrogen sulfide and sodium sulfide. Your diagrams should show chemical symbols of the elements and ionic charges where appropriate.

hydrogen sulfide

sodium sulfide

- (c) Petroleum (crude oil) contains dissolved hydrogen sulfide which has to be removed.

The symbol equation below shows a reaction that is involved in the removal process.

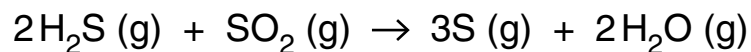

- (i) State the total number of hydrogen and sulfur atoms shown on the left hand side (the reactants) of the equation above.

hydrogen

sulfur

[1]

- (ii) Explain why the physical state symbols, (g), show that this reaction occurs at a high temperature.

.....

.....

..... [2]

Please turn over for Question 3.

3 Fig. 3.1 shows part of the carbon cycle.

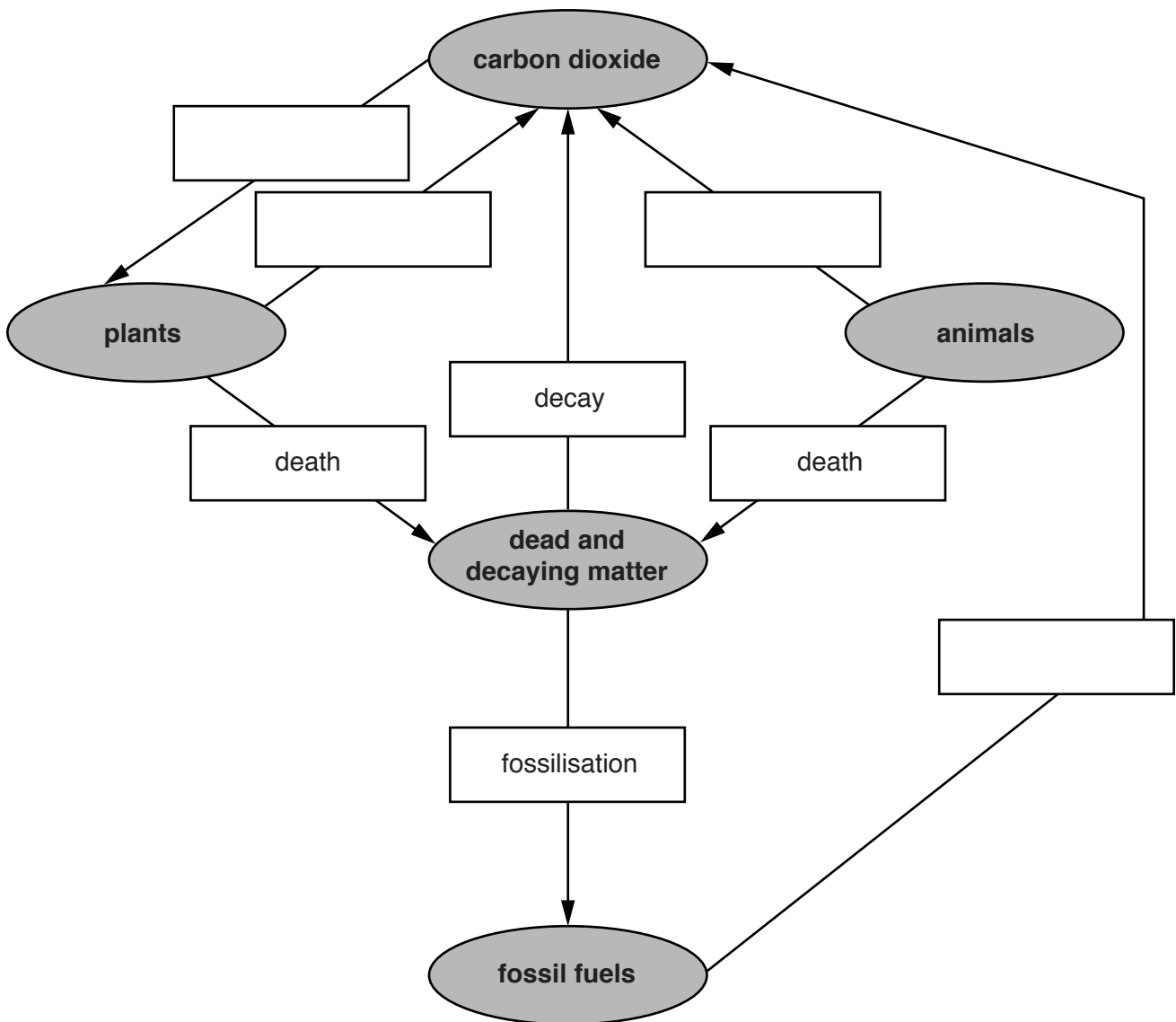

Fig. 3.1

(a) Fill in the empty boxes in Fig. 3.1, naming the processes involved in the carbon cycle. Choose words from this list.

You may use each word once, more than once, or not at all.

breathing	combustion	decomposition
photosynthesis	respiration	transpiration

[4]

(b) Add an arrow to Fig. 3.1 to show how animals obtain their carbon.

[1]

(c) Explain why an ecosystem needs an external supply of energy from sunlight, but does not need an external supply of carbon atoms.

.....
.....
..... [1]

(d) Use the idea of the carbon cycle to suggest an explanation for each of the following.

(i) In a deciduous (temperate) forest, the carbon dioxide concentration in the atmosphere falls slightly in spring and summer, and then rises again in the autumn.

.....
.....
.....
..... [2]

(ii) Cutting down rainforests might lead to an increase in the carbon dioxide concentration in the Earth's atmosphere.

.....
.....
..... [2]

(iii) Combustion of fossil fuels is more harmful to the environment than combustion of wood.

.....
.....
..... [2]

- 4 (a) Fig. 4.1 shows the chemical symbols of some elements in the first four periods of the Periodic Table.

Li															F	Ne	
K							Fe			Cu					Br		

Fig. 4.1

Using only those **symbols** shown in Fig. 4.1, complete Table 4.1 with the **element or elements** that match the descriptions in the column on the left.

Each symbol may be used once, more than once or not at all.

Table 4.1

description	element symbol(s)
it is a halogen that is more reactive than chlorine	
it may be used as a catalyst in the Haber Process	
its atoms have all electron shells filled	
their atoms have four electron shells	
they are good electrical conductors	
they are transition elements	

[6]

(b) (i) Calculate the mass of 0.2 moles of zinc.

The proton number of zinc is 30 and its relative atomic mass may be found in the Periodic Table on page 32.

Show your working and state the unit of your answer.

..... unit [2]

(ii) State what 0.2 moles of zinc has in common with 0.2 moles of any other element.

.....
..... [1]

5 A student measures the heights of all the pupils in her class, and records them to the nearest centimetre. Fig. 5.1 shows her results.

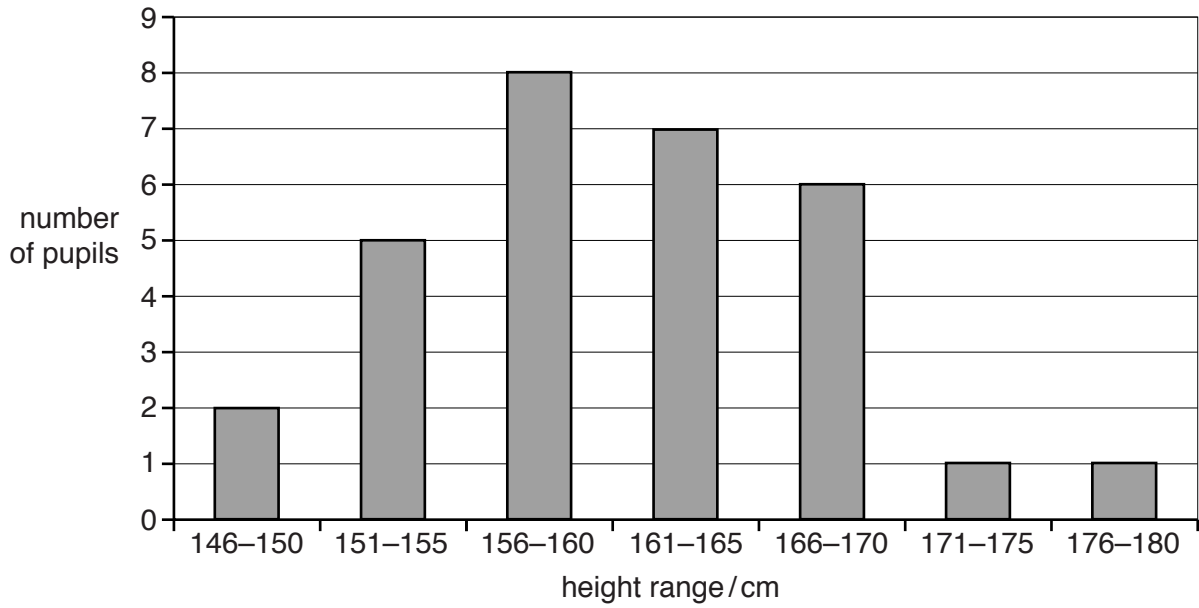

Fig. 5.1

(a) (i) State the most common height range recorded for this group of pupils.

..... [1]

(ii) Calculate the total number of pupils in the class.

number of pupils [1]

(b) Name the type of variation shown in Fig. 5.1.

..... [1]

(c) Two of the pupils in the class are identical twins.

This means they developed from the same fertilised egg. Despite this, they are of slightly different heights.

(i) Suggest what may have caused them to be of different heights.

.....
..... [1]

(ii) Explain why these twins, although of slightly different heights, will almost certainly be of very **similar** heights.

.....
..... [1]

(d) State **two** ways in which variation in blood groups in humans is different from variation in height.

1
2 [2]

- 6 (a) During car journeys, a car becomes electrostatically charged. This is more obvious on a dry day than on a damp, humid day.

On a warm dry day, the potential difference between the driver and the car increases to 10000V.

- (i) Explain what happens to cause the car to become charged.

.....

 [2]

- (ii) As the driver touches the car door on a warm and dry day, he gets an electric shock and 24 millijoules (0.024 J) is transferred between the driver and the car.

If the discharge lasts for 0.030 milliseconds, calculate the power associated with the discharge.

State the formula that you use and show your working.

formula

working

power = W [2]

- (iii) Using your answer to (ii) calculate the current which passes through the driver during the discharge.

State the formula that you use and show your working.

formula

working

current = A [2]

(b) A car has two headlamps connected in parallel with each other across a 12V battery.

Each headlamp has a resistance of 3Ω .

Calculate the combined resistance of the two lamps connected in parallel.

State the formula that you use and show your working.

formula

working

combined resistance = Ω [2]

(c) A police car uses a blue light and a loud sound from a siren to alert people.

(i) State how the sound from the siren changes when the amplitude of the sound waves emitted decreases.

..... [1]

(ii) Sound waves are longitudinal waves but light waves are transverse waves.

Describe the difference between a transverse wave and a longitudinal wave. You may draw diagrams if it helps your answer.

.....
.....
..... [2]

(d) The alternator in the car is an a.c. generator.

Fig. 6.1 shows a simple a.c. generator.

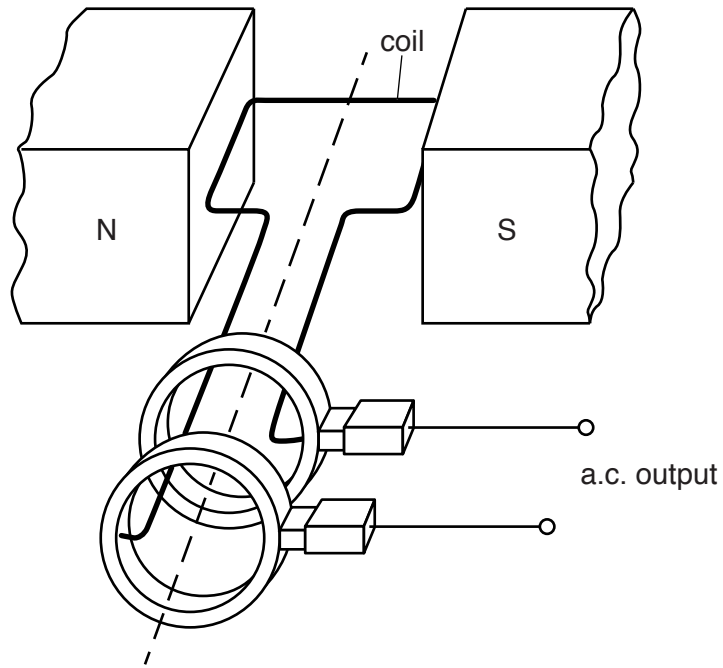

Fig. 6.1

Describe how the rotation of the coil in the magnetic field and the use of slip rings produce an alternating current.

.....

.....

.....

.....

..... [3]

- 7 Fig. 7.1 shows four pea seeds inside a pod. The pod is the fruit of the pea plant. One of the pea seeds inside it is shown in section.

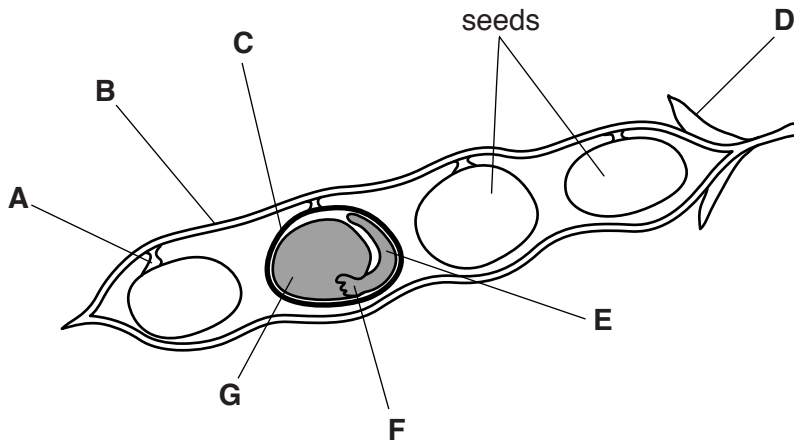

Fig. 7.1

Identify which letter in Fig. 7.1 labels

a cotyledon,

the fruit wall,

the radicle,

the testa.

[4]

- 8 The percentages of chemical elements found in the Earth's crust and in the Earth's atmosphere are shown in Fig. 8.1.

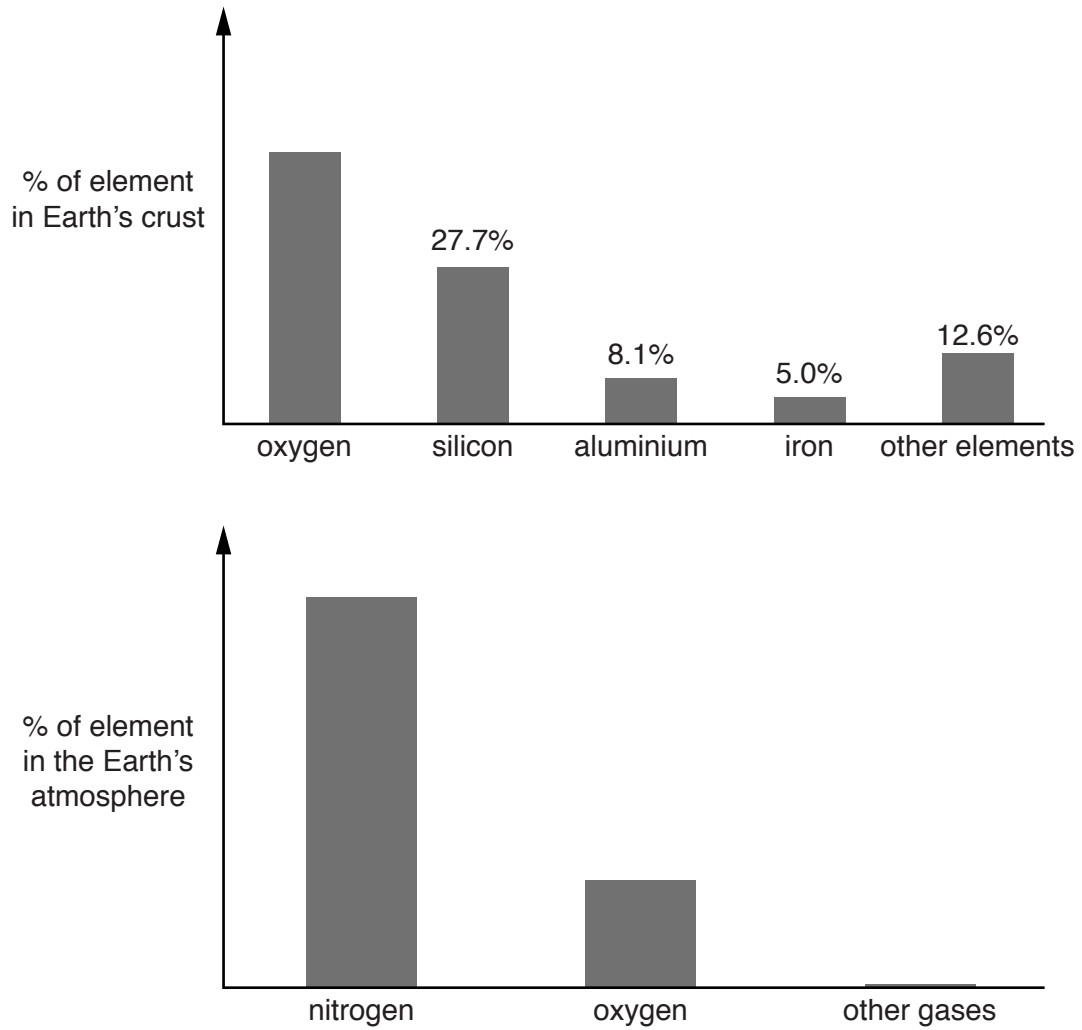

Fig. 8.1

- (a) Deduce whether the Earth's crust or atmosphere contains the greater percentage of oxygen.

.....
..... [2]

- (b) Fig. 8.2 shows the chemical structures of two substances, **R** and **S**, that contain oxygen atoms.

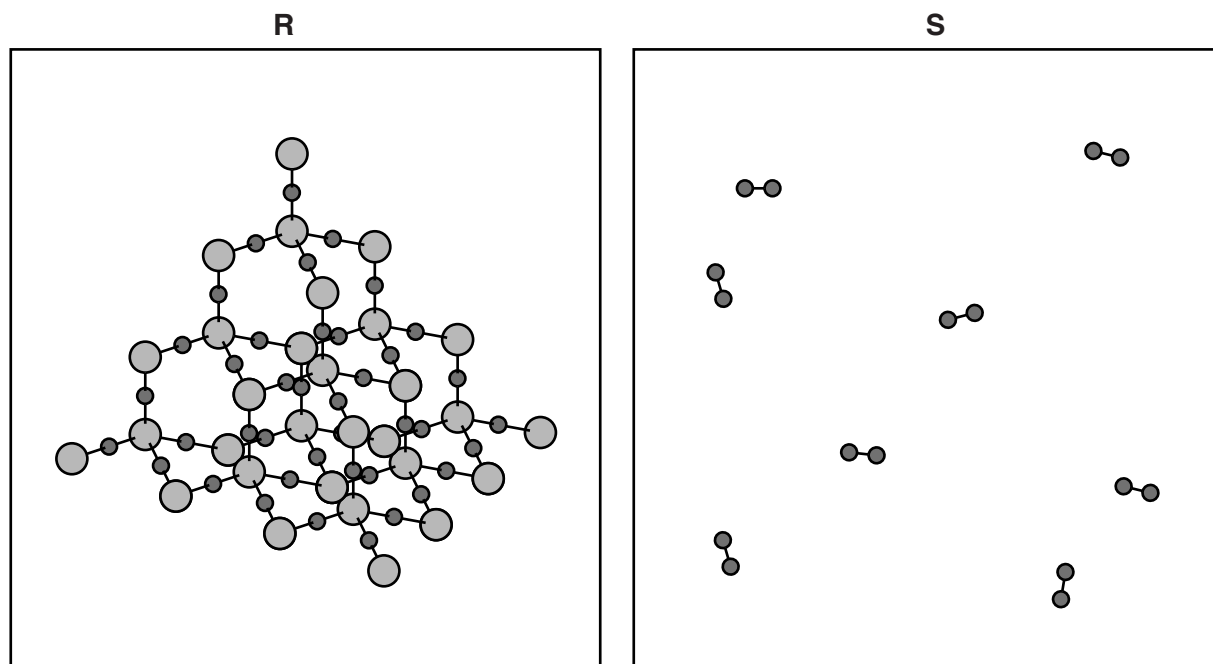

Fig. 8.2

State and explain which structure, **R** or **S**, shows a substance that is found in the Earth's crust and **not** in the atmosphere.

structure

explanation

.....

..... [2]

- (c) Aluminium and iron are obtained from their oxides.

- (i) Write a **word** equation for a reaction in the blast furnace that produces iron from iron oxide.

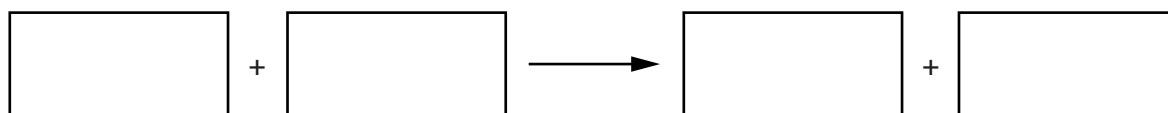

[2]

- (ii) Fig. 8.3 shows a simplified diagram of the industrial apparatus that is used to obtain aluminium.

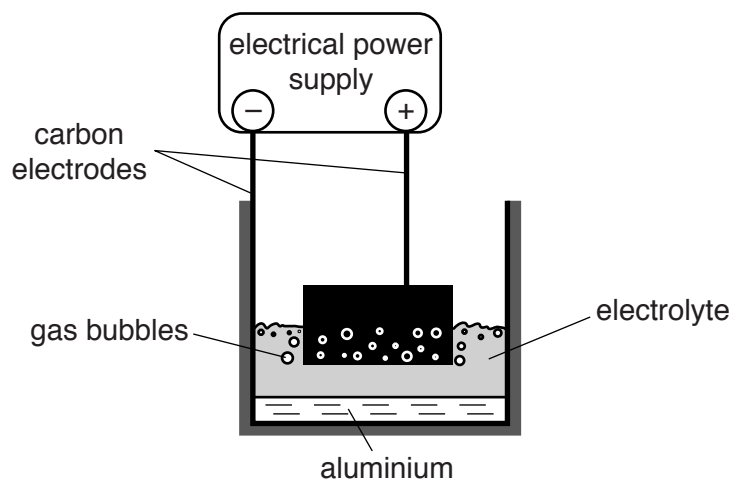

Fig. 8.3

Describe how aluminium ions, Al^{3+} , are changed when they come into contact with the surface of the cathode.

.....

.....

..... [2]

9 (a) Dolphins communicate with each other under water using sound waves.

(i) Sound waves travel through water as a series of compressions and rarefactions.

Describe the difference between a compression and a rarefaction.

.....
..... [1]

(ii) The speed of sound in air is 330 m/s. In water the speed of sound is about 1500 m/s.

Suggest why the speed of sound is greater in water than in air. Use ideas about the distances between molecules and the movement of molecules in your answer.

.....
.....
.....
..... [2]

(b) The water in the sea is heated by the Sun.

Some molecules of the water evaporate. The water does not boil.

State **two** ways in which boiling differs from evaporation.

1
.....
2
..... [2]

(c) Fig. 9.1 shows three different ways in which particles may be arranged in substances.

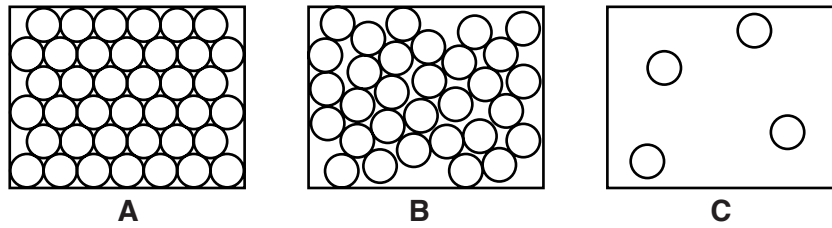

Fig. 9.1

Water in the sea is a liquid and water in the air is a gas.

(i) State which diagram best represents the way particles are arranged in liquid water.

Explain your answer.

diagram

explanation

..... [1]

(ii) State which diagram best represents the way particles are arranged in gaseous air.

Explain your answer.

diagram

explanation

..... [1]

10 Fig. 10.1 shows a root hair cell from a plant.

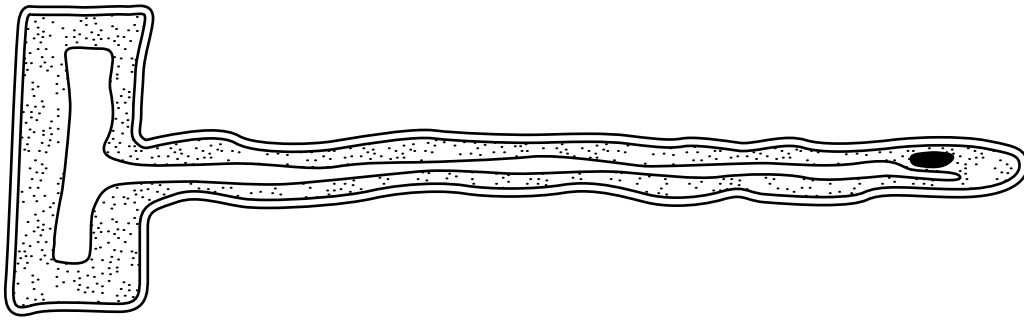

Fig. 10.1

(a) Name and describe the process by which the root hair cell absorbs water from the soil.

name

description

.....

..... [3]

(b) State **one** other function of the root hair cell.

..... [1]

(c) Describe how the shape of a root hair cell helps it to absorb water from the soil.

.....

..... [1]

(d) Most of the water absorbed by the root hair cell later evaporates from the plant. State where most of this evaporation occurs.

..... [1]

(e) Not all of the water absorbed by a plant is lost by evaporation. Suggest **two** ways in which a plant might make use of the absorbed water.

1

2 [2]

(f) Many plant cells contain chloroplasts. Explain why root hair cells **do not** contain chloroplasts.

.....

..... [1]

11 Hydrocarbons are described in terms of the homologous series to which they belong.

Two homologous series are alkanes and alkenes.

Alkanes are found in petroleum (crude oil). Alkenes are produced in the chemical industry.

(a) Fig. 11.1 shows the structure of one molecule of a hydrocarbon.

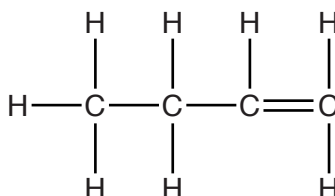

Fig. 11.1

(i) State and explain whether this hydrocarbon is an alkane or an alkene.

this hydrocarbon is an

explanation

..... [1]

(ii) Describe what would be observed when this hydrocarbon is shaken with a solution of bromine.

.....

..... [1]

(b) Describe the process by which alkenes are manufactured in the chemical industry.

name of process

description

.....

.....

..... [4]

- (c) When gaseous ethene, C_2H_4 , at a high pressure is heated with a catalyst, it reacts to produce a white solid.

The relative molecular masses of ethene and the white solid are shown below.

	ethene	white solid
relative molecular mass	28	200 000 (an average value)

- (i) Show that the relative molecular mass of ethene is 28.

[1]

- (ii) Explain why the white solid has a much higher relative molecular mass than ethene. You may draw a diagram to show what happens in the reaction if it will help you to answer this question.

.....

 [2]

- (iii) Suggest why only an average value rather than an exact value for the relative molecular mass of the white solid can be stated.

.....

 [2]

12 Table 12.1 shows the death rates from coronary heart disease in two different countries between 2010 and 2013.

Table 12.1

year	deaths per 100 000 people	
	country A	country B
2010	125	144
2011	114	146
2012	120	137
2013	98	145

(a) State **two** ways in which the death rate from coronary heart disease in country **B** differs from that in country **A**.

- 1
- 2 [2]

(b) In country **B**, the average age of the population is greater. Explain why this would affect the death rate from coronary heart disease.

-
-
- [1]

(c) State **two** ways in which a person's diet could increase their chance of suffering from coronary heart disease.

- 1
- 2 [2]

(d) Suggest two other possible reasons (apart from differences of age or diet) for the difference in the rates of coronary heart disease in these two countries.

- 1
- 2 [2]

(e) Explain why, when comparing the two countries, it is important to express the death rates per 100 000 people, instead of just giving the total number of deaths in each country.

-
- [1]

13 (a) A doctor uses both X-rays and γ -(gamma) rays in a hospital.

(i) X-rays and γ -rays are both part of the electromagnetic spectrum.

Write each one in its correct box on the incomplete electromagnetic spectrum below.

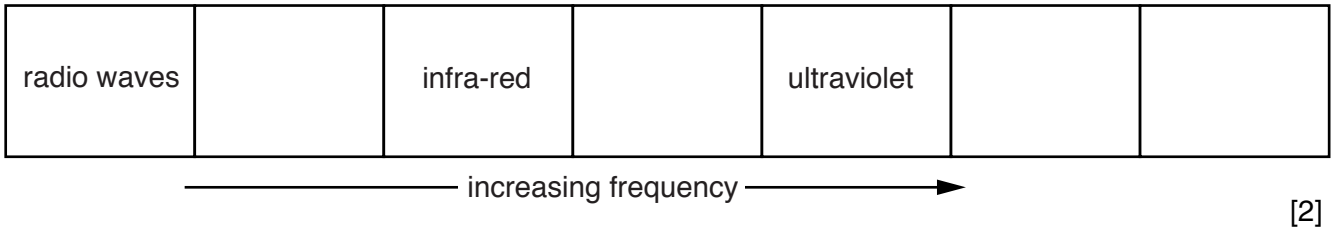

[2]

(ii) State the speed of all electromagnetic waves in km/s.

..... km/s [1]

(b) To study the blood flow in a patient's lungs, the patient is injected with a radioactive isotope, technetium-99. The γ -radiation given out by the technetium-99 is detected using a gamma camera outside the patient's body.

(i) Identify all of the statements that explain why γ -radiation is used for this investigation. Place a tick in the correct box or boxes.

It can pass through the human body.

It destroys cancer cells.

It is safer than α - or β -radiation.

[1]

- (ii) The label shown in Fig. 13.1 gives some information about the radioactive isotope technetium-99.

type of radiation emitted - gamma
half life - 6 hours
use as a medical tracer

Fig. 13.1

The graph in Fig. 13.2 is incomplete. It should show the count rate from a sample of technetium-99 changing with time.

At the start, the count rate is 400 counts per minute. This point is plotted on the graph.

Plot points to show the count rate after one half-life, after two half-lives and after three half-lives and then draw a smooth curve linking the plotted points.

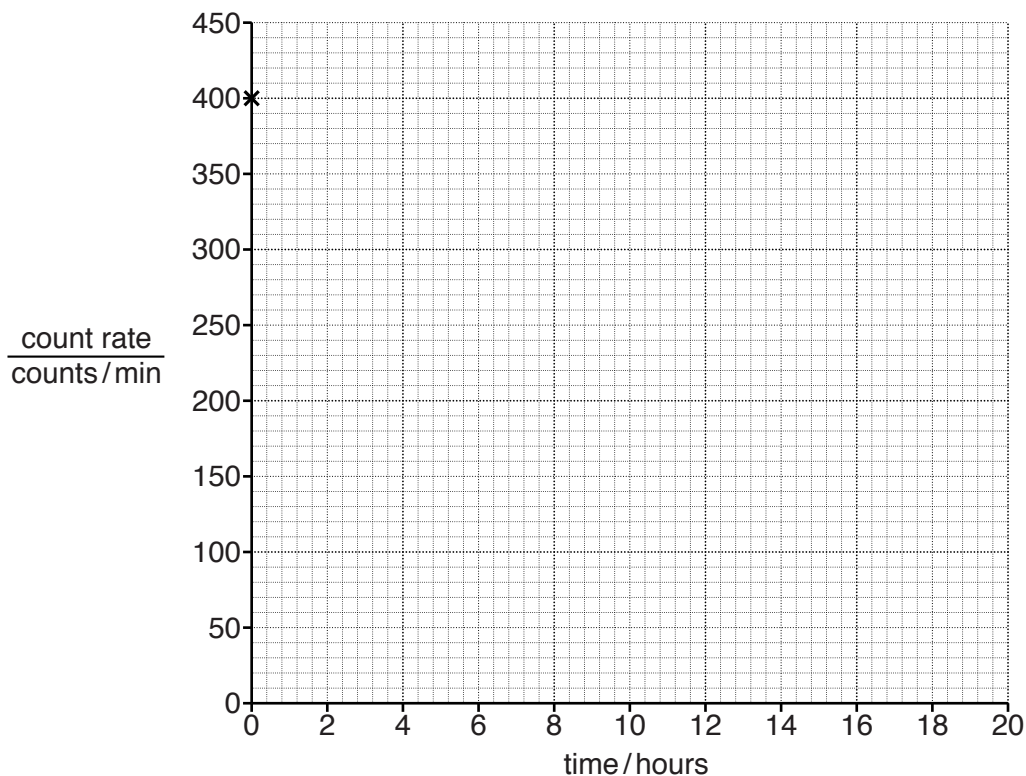

Fig. 13.2

[3]

- (c) Optical fibres are used to see inside the human stomach. Light is sent along a bundle of fibres to enable the doctor to see what is in the stomach.

Fig. 13.3 shows an endoscope being used by the doctor to see inside a patient's stomach.

It contains a bundle of optical fibres.

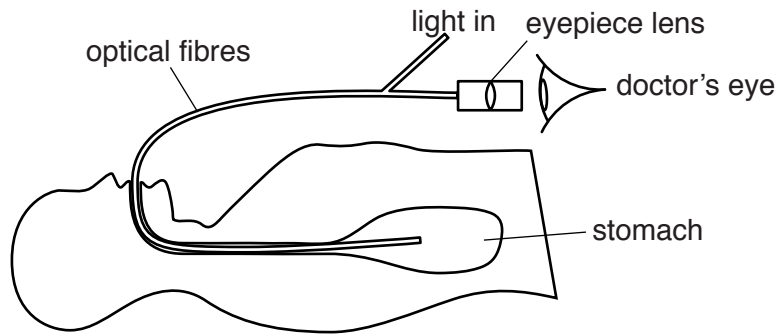

Fig. 13.3

The sentences in Table 13.1 describe how an endoscope allows the doctor to see inside a patient's stomach. These sentences are in the wrong order.

Write the numbers 2, 3, 4 and 5 in the right hand column to indicate the correct order of the sentences. The sentence for the first stage has been identified for you.

Table 13.1

A bundle of optical fibres takes the light to an eyepiece lens.	
Light passes through a bundle of optical fibres into the patient's stomach.	1
The doctor looks through the eyepiece lens to see the inside of the patient's stomach.	
The inside of the stomach reflects some of the light.	
The reflected light passes into a bundle of optical fibres.	

[2]

DATA SHEET
The Periodic Table of the Elements

		Group									
I	II	III	IV	V	VI	VII	0				
		1 H Hydrogen 1					4 He Helium 2				
7 Li Lithium 3	9 Be Beryllium 4		11 B Boron 5	12 C Carbon 6	14 N Nitrogen 7	16 O Oxygen 8	19 F Fluorine 9	20 Ne Neon 10			
23 Na Sodium 11	24 Mg Magnesium 12		27 Al Aluminium 13	28 Si Silicon 14	31 P Phosphorus 15	32 S Sulfur 16	35.5 Cl Chlorine 17	40 Ar Argon 18			
39 K Potassium 19	40 Ca Calcium 20		70 Ga Gallium 31	73 Ge Germanium 32	75 As Arsenic 33	79 Se Selenium 34	80 Br Bromine 35	84 Kr Krypton 36			
85 Rb Rubidium 37	88 Sr Strontium 38		115 In Indium 49	119 Sn Tin 50	122 Sb Antimony 51	128 Te Tellurium 52	127 I Iodine 53	131 Xe Xenon 54			
133 Cs Caesium 55	137 Ba Barium 56		204 Tl Thallium 81	207 Pb Lead 82	209 Bi Bismuth 83	210 Po Polonium 84	210 At Astatine 85	222 Rn Radon 86			
223 Fr Francium 87	226 Ra Radium 88		65 Zn Zinc 30	64 Cu Copper 29	59 Ni Nickel 28	56 Fe Iron 26	59 Co Cobalt 27	55 Mn Manganese 25	48 Ti Titanium 22	45 Sc Scandium 21	
			112 Cd Cadmium 48	108 Ag Silver 47	106 Pd Palladium 46	101 Ru Ruthenium 44	103 Rh Rhodium 45	96 Mo Molybdenum 42	91 Zr Zirconium 40	89 Y Yttrium 39	
			201 Hg Mercury 80	197 Au Gold 79	195 Pt Platinum 78	190 Os Osmium 76	192 Ir Iridium 77	184 W Tungsten 74	178 Hf Hafnium 72	139 La Lanthanum 57	
			159 Tb Terbium 65	157 Gd Gadolinium 64	152 Eu Europium 63	147 Pm Promethium 61	150 Sm Samarium 62	144 Nd Neodymium 60	141 Pr Praseodymium 59	227 Ac Actinium 89	
			169 Tm Thulium 69	165 Ho Holmium 67	162 Dy Dysprosium 66	152 Eu Europium 63	147 Pm Promethium 61	144 Nd Neodymium 60	141 Pr Praseodymium 59		
			258 Md Mendelevium 101	252 Es Einsteinium 99	251 Cf Californium 98	237 Np Neptunium 93	244 Pu Plutonium 94	238 U Uranium 92	231 Pa Protactinium 91		
			260 Lr Lawrencium 103	260 Lr Lawrencium 103	260 Lr Lawrencium 103	260 Lr Lawrencium 103	260 Lr Lawrencium 103	260 Lr Lawrencium 103	260 Lr Lawrencium 103		
			259 No Nobelium 102	259 No Nobelium 102	259 No Nobelium 102	259 No Nobelium 102	259 No Nobelium 102	259 No Nobelium 102	259 No Nobelium 102		
			173 Yb Ytterbium 70	173 Yb Ytterbium 70	173 Yb Ytterbium 70	173 Yb Ytterbium 70	173 Yb Ytterbium 70	173 Yb Ytterbium 70	173 Yb Ytterbium 70		
			175 Lu Lutetium 71	175 Lu Lutetium 71	175 Lu Lutetium 71	175 Lu Lutetium 71	175 Lu Lutetium 71	175 Lu Lutetium 71	175 Lu Lutetium 71		

* 58–71 Lanthanoid series
† 90–103 Actinoid series

Key

a	X
b	

a = relative atomic mass
X = atomic symbol
b = atomic (proton) number

The volume of one mole of any gas is 24 dm³ at room temperature and pressure (r.t.p.).